

Eliminating an avian pest (House Sparrow *Passer domesticus*) population: the role of trapping at a homestead scale

David B McGregor¹ and Bruce A McGregor²

¹Glenloch, RMB 4160, Boorolite, via Mansfield, Victoria 3723.

²103 Mitchell St., Brunswick, Victoria 3056. Email address: mcgregor@sub.net.au

²Corresponding author

Abstract

In the absence of Australian data about methods to control House Sparrows *Passer domesticus* this paper investigates the role of harbour removal and trapping to eliminate a House Sparrow infestation from a farm property near Mansfield, Victoria. Over 23 years, 630 House Sparrows were captured and the property has had no resident sparrows for 13 years. Benefits from the removal of House Sparrows are listed. Over the past 10 years, records of captured dispersing House Sparrows from other locations indicate that 85% of these birds arrived during summer and less than 1% during mid-winter to late spring. Once resident sparrow numbers were reduced to zero, birds arriving appeared nervous and usually dispersed before the trap was set. Based on this work, trapping is most effective during the dispersal period. These findings should encourage others to view House Sparrows as pests that can be eliminated with judicious trapping (care, skill and observation) and the removal of harbours. It is proposed that the effective use of trapping over a catchment scale based on homestead action should be able to reduce or eliminate House Sparrows from Australia. (*The Victorian Naturalist* 125 (1), 2008, 4-10)

Introduction

The House Sparrow *Passer domesticus* is a native bird of northern Africa and Eurasia that has been introduced to the Americas and Australia (Blakers *et al.* 1984). In North America, the House Sparrow was one of eight species with the highest ranking of 48 potential exotic pests evaluated for invasive potential (Smallwood and Salmon 1992). The speed of colonisation has been measured at up to 105 km/year in Australia (Barrett *et al.* 2003) and island hopping in the Caribbean (Clergeau *et al.* 2004) and Norway (Jensen *et al.* 2004) could be of similar magnitude. While House Sparrows are known agricultural pests that cause damage to grain crops, poultry rations, storage sheds, livestock feedlots, fruit trees, sprouting vegetables and amenity flowers, they also compete with native birds for food, and spread diseases and parasites (Bryant 2002, Kern 2003, McInerney 2004).

House Sparrows were introduced to Australia in about 1861 (Gillbank 2001) and in 1872-1874 the Cincinnati Acclimatization Society introduced House Sparrows into the USA (Bryant 2002). In Australia, House Sparrows significantly increased the area they occupied during the twentieth century (Blakers *et al.* 1984) and now occupy about one half of the

Australian land area (Barrett *et al.* 2003). House Sparrows are now so conspicuous that they ranked 31st on the list of most frequently reported species in the recent Atlas of Australian Birds (Barrett *et al.* 2003). Over recent decades the ecology of House Sparrows and the impact of and problems caused by House Sparrows in Australia have rarely been discussed.

Rolls (1984) states that by 1876 it was realised that it had been a mistake to introduce House Sparrows into Australia. They had become such a nuisance that 'clubs had been formed in Victoria for their destruction, and rewards were offered for both eggs and dead birds'. It is no wonder then that a Farmers Handbook (Anon 1934, 1978), reports that many people used traps and poisoning to reduce sparrow numbers. This Handbook provided plans for a sparrow trap and advised that 'sparrow traps of similar design have given great satisfaction'. However, this claim is unsubstantiated and has been questioned by the government department responsible for fauna conservation: 'Needless to say, it hasn't proven very effective in controlling the sparrow population' (Anon 1995). It appears that Australian wildlife and ecological specialists in the tropics hold the view that poisoning is the only method to

control sparrows, as Harrison and Congdon (2002) concluded that the close association of House Sparrows with human settlements, the difficulty of control and the probable detrimental effects of control measures (poison) on urban native species, means that the overall pest status of this species was unlikely to change. Neither Anon (1995) nor Harrison and Congdon (2002) provide any evidence that trapping is unsuccessful or that poisoning is safe.

Donlan *et al.* (2003) reviewed scientific articles published between 1991 and 2002 on the eradication of invasive exotic species and found no articles dealing with research on eradication techniques. They concluded that the bias in the literature is impeding conservation action against the effects of invasive species and called for four actions to overcome this bias including evaluating existing tools for invasive-species eradication. According to Donlan *et al.* (2003), while there are significant examples demonstrating the value of eradicating invasive species, the use of eradication as a technique remains on the fringe of conservation circles, and they call for further development of this powerful tool by the publishing of supporting research. This call has been echoed by Cruz *et al.* (2005).

Given House Sparrows are highly invasive and there is a lack of objective information concerning their removal, particularly efficacy of trapping, here we report on the operation and effectiveness of trapping as a control measure. This article also provides some details of House Sparrow dispersal in south-eastern Australian farmland.

Methods

The aim of this work was to eliminate House Sparrows from a farm property in south-eastern Australia. The 65 ha grazing property was 18 km south-south-east of Mansfield, Victoria, Australia (37°09'43"S., 146°11'76"E., elevation 400 m). The native vegetation was almost completely cleared in the early twentieth century, with only a few mature *Eucalyptus* spp. remaining in the paddocks, while the roadsides contain good numbers of Peppermint Gums *E. dives*, with some Blackwood wattles *Acacia melanoxylon*, Tree Violets *Hymenantha dentata* and tea-trees *Leptospermum* spp. Daily rainfall was

recorded. When purchased in autumn 1979 the homestead was poorly maintained and the run-down garden contained a mature orchard, Radiata Pines *Pinus radiata* and six Chusan (Windmill) Palms *Trachycarpus fortunei*. The trunks of Chusan Palms were clothed in dense fibre and old leaf sheaths. Mature Chusan Palms produce large quantities of black berries. The nearest three neighbouring houses were approximately 200, 400 and 1000 m away. Since this time, two new houses have been constructed at approximately 600 and 800 m.

Methods of control included harbour removal and trapping. As sparrows were using the house for roosting, the following actions were taken to reduce harbours: roof ventilation eaves and entrances to the ceiling space were blocked with fly wire; entrances to wall cavities were timbered over; canvas verandah blinds were removed as birds were nesting in the ends of the rolls; as sparrows were breeding in the tops of the 6 m high Palms, the Palms were removed in winter; domestic chickens were not kept after 1989.

A Weekly Times Sparrow trap (Anon. 1978) was constructed (Fig. 1) and operated from early 1983. Across the framework at the bottom of the V is a strip of wire netting between 7 and 10 cm above the ground, 'the height must not exceed 10 cm', presumably to prevent birds turning over and escaping. At intervals along the middle of it are three holes 2.5 to 4 cm in diameter. The trap was operated by sprinkling wheat grain on the ground under the central V. Inquisitive birds jump down through one of the enlarged reinforced holes. The sides of the V are solid. Once inside, the birds are attracted to the light at either end of the trap in order to escape. Once in the enlarged 'box' ends the birds may flit from end to end without perceiving the entrance holes which are over-shadowed by the solid sides of the V. The openings on each end are to admit an arm to capture and remove sparrows. Captured House Sparrows were humanely killed.

The trap was placed within 10 m of the house where it was under easy surveillance. When close supervision was not possible the trap entrance was sealed off with a heavy board or the trap was overturned. Daily records of trapping operation

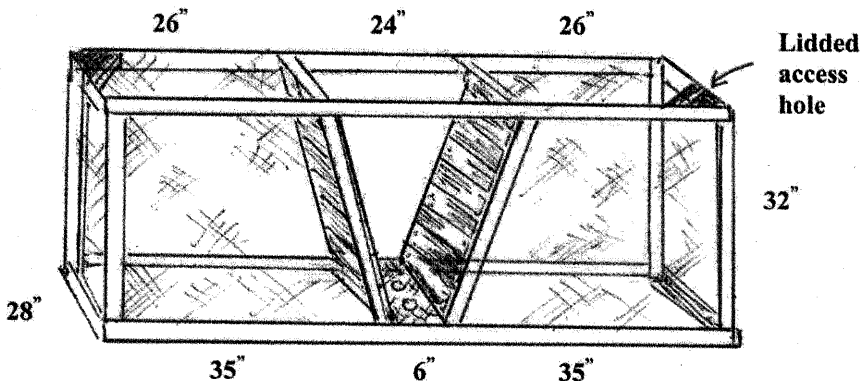

Fig. 1. The Weekly Times sparrow trap showing the central V with entrance holes. Dimensions shown in inches accord with those published by Anon (1978). One inch equals 2.5 cm.

and trapping success were kept. Observations of bird age and behaviour were kept.

Results

Rainfall is shown in Fig. 2. Mean \pm s.d. annual rainfall during the period was 815 \pm 170 mm.

Harbour removal was 100% effective in preventing roosting in the house ceiling space. The noise and constant chirruping of roosting sparrows was eliminated. The felling of the palms revealed masses of sparrow nesting material. As a result of these measures, few sparrows were seen sitting on the gutters used to collect domestic drinking water.

From its initial operation, the trap was effective in capturing House Sparrows. During the period of operation 643 sparrows were caught. The trapping results show a cyclical pattern (Fig. 3). From 1994 the numbers trapped declined to zero and it was not until 1999 that small numbers were again seen and captured.

The majority of sparrows were caught in summer (85%, Fig. 4). Since 1992, 90% of captured birds were immature individuals or juveniles with retained yellow fleshy gapes. Juvenile birds usually entered the trap promptly. Trappings during autumn and early winter amounted to 14%. Less than 1% of captures were during midwinter to late spring (July-November).

Once resident sparrow numbers were reduced to zero, birds arriving in summer

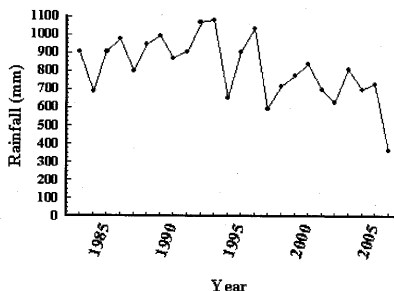

and autumn appeared nervous. Often the small numbers (often only one) would not stay and the sparrows dispersed before the trap could be set and supervised. There were long periods when no sparrows were observed and the trap was not set. Other small native birds such as Superb Blue Wrens, White-browed Scrub Wrens and Red-browed Firetails were rarely, but sometimes, captured in the trap, as these birds are also inquisitive explorers. Thus supervision during the day was required to release these 'by-catch' birds without delay. A few sparrows learnt to escape. These birds were captured by the operator working in the garden nearby and keeping the trap under very close observation.

When neighbours, who were unaware of the trapping program, were asked about numbers of sparrows at their homesteads, they replied that there were 'not many seen lately'.

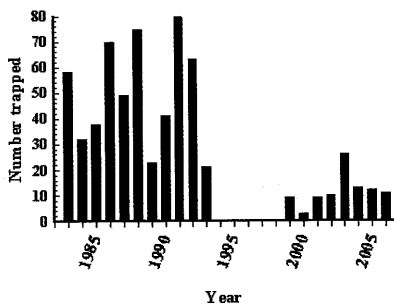

Fig. 3. The number of sparrows trapped each year from 1983 to 2006.

Discussion

We have shown that it is possible to operate a trap to depopulate a locality of House Sparrows associated with a rural dwelling. This property has had no resident House Sparrows since 1993 (over 13 years). This experience accords with the observations made in the Weekly Times Handbook that 'Experience has shown that the birds usually keep to one locality, and if measures are taken during winter and autumn, when food is scarce, their numbers can be greatly reduced' (Anon 1978, p 189).

From an ecological perspective, what was the effective locality in the present case? If the area depopulated by this single trap is assumed to include the neighbouring properties, then a total area of 600 ha may have been cleared or substantially cleared. Further work is required to substantiate this observation.

The continuing construction of buildings and homes in rural Australia is providing more habitats for House Sparrows. The increasing number of residences also provides the opportunity for the strategic location of traps to allow depopulation of wider areas. An opposite trend in House Sparrow populations may be evident in rural areas where farm amalgamation is leading to the abandonment of homesteads with a reduction of suitable habitat. Evidence for this is provided by analysis of data from *The New Atlas of Australian Birds* (C Tzaros 2005 pers. comm.).

The ability to depopulate a rural area with a single trap has implications for ecological restoration. This experience contrasts sharply with the conclusions of previous

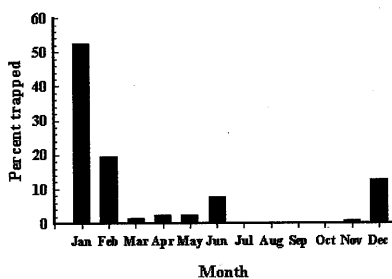

Fig. 4. The percentage of sparrows trapped by month of the year for the period 1992-2006 (n = 118).

reports (Anon 1995; Harrison and Congdon 2002) and challenges the notion of Harrison and Congdon (2002) that poisoning is the only method of removal of House Sparrows. It is possible to change the pest status of House Sparrows on a local scale from residents to uncommon seasonal visitors. This is not an unreasonable strategy as House Sparrows are closely associated with humans (Long 1981; Blakers *et al.* 1984). We therefore propose the hypothesis that, in rural areas, control at the homestead level is the most appropriate scale for effective elimination of House Sparrows.

It took some years to depopulate the home area. House Sparrows can live for at least six years (Jensen *et al.* 2004). It is suspected that the sudden collapse of sparrow numbers in 1994 was because of the death of mature breeding birds due to old age, as a large proportion of trapped sparrows in the years just prior to 1994 had been yellow-gaped juveniles dispersing to new areas. Using the methods described to depopulate the home areas therefore involves the removal of all adult sparrows, their offspring, any dispersing sparrows from neighbouring areas, and harbour removal. The complete depopulation of sparrows lasted for five years (1994-1998), before further trapping was required.

A number of issues have not been controlled in this study. For example, the food supply from domestic chickens, dogs and cats would have varied according to the number of houses in the neighbouring area or the preferences of occupants in those houses. Thus the increased number of House Sparrows trapped from 1999 may

be related to the establishment of populations at the new houses. A wider survey would be of interest.

Clearly an area that has been depopulated of House Sparrows can be re-infested by dispersing juvenile birds. Re-infestation in this locality occurred only in midsummer. It is unclear if further trapping was actually required to capture the dispersing House Sparrows that arrived from 1999 but the risk of not trapping could undermine work to eliminate the original population. The fate of dispersing House Sparrows seen at the homestead but not trapped is unknown.

How far House Sparrows can disperse in one season is not clear. Blakers *et al.* (1984) provide observations that imply dispersal rates of 6.7 km/year in arid areas of South Australia to 85 to 103 km/year in settled farmland in Queensland. In Boorlote, dispersal was not always successful as five years passed between elimination and re-colonisation as suggested by trapping. During this five-year period, House Sparrows passed through this farm but did not stay. The failure of these dispersing House Sparrows to adopt a potential new home suggests factors other than the presence of humans affects the attractiveness of a potential new habitat.

It is relevant when promoting the trapping of House Sparrows to other rural landholders that the benefits arising to them from the removal of House Sparrows should be carefully explained. The removal of sparrows in this work was associated with an improved amenity in four areas.

1. Noise. The incessant chirruping of the sparrows was eliminated. This was particularly noticed at dawn but also during flocking and breeding times.
2. Health and water quality. There was complete removal of sparrow faeces, nesting material and feathers from the verandahs, ceiling, roof, spouting and tanks. Sparrows commonly rest on gutters and roost in roof spaces. This is associated with defecation into the water supply of the household. While no records were kept of *Escherichia coli* levels in the water supply, there was no risk of infection from House Sparrows as they were no longer present. A detailed study of this aspect of risks to

human health would be of interest. There are more than 60 transmittable diseases that are associated with pigeons, starlings and sparrows. In New Zealand, House Sparrows have been implicated in maintaining and spreading *Giardia* and *Cryptosporidium* infections on farms (Chilvers *et al.* 1998). Alley *et al.* (2002) reported an outbreak of salmonellosis due to *Salmonella typhimurium* DT160 which caused extensive mortality in wild birds and enteric disease in humans in New Zealand. Isolates from birds, livestock and humans were indistinguishable from one another. Because of the close association between House Sparrows and humans, Alley *et al.* (2002) concluded that the organism poses a serious zoonotic risk. Bird droppings can contain pathogenic fungi and bacteria that cause histoplasmosis, chlamydiosis, cryptococcosis and other lung diseases in humans (Anon 2005). Commercial pest control companies in Australia advise that bird droppings in areas such as external air-conditioning units, window ledges, pathways, water treatment or supply systems, and pedestrian entrances should be removed as soon as possible, to eliminate possible health and safety risks to the public.

3. Improved growth in the vegetable garden. Sparrows eat emerging seedlings of lettuce, beetroot etc. Replanting these seedlings loses three weeks in an already short season between the chill of winter and the heat of summer.
4. A return of native birds, particularly finches. Long (1981) reported that House Sparrow distribution is aided by human activity and that throughout this range they are not known to have competitively replaced native species in undisturbed habitat, although some species displacement must have occurred. However Blakers *et al.* (1984) state that House Sparrows 'often drive native birds from nest sites'. In the present study, the removal of the House Sparrows was associated with the return of native finches. Sparrows are territorial in the sense that they closely follow human settlement (Blakers *et al.* 1984). The return of finches may have been circumstantial or associated with the provision of plan-

tations, and fenced-off areas with long ungrazed grass etc. However in the 14 years prior to the removal of House Sparrows, no native finches had been seen on the farm.

The trap was easily made and worked effectively. All that was required was to keep up the supply of bait and to effectively supervise the trap. Traps work because of the behaviour of sparrows that chirrup to bring in other individuals when they find a new food resource that is divisible (Elgar 1986). Sparrows prefer to be in flocks. Individual sparrows appear nervous and are clearly more vulnerable to predators (Harkin *et al.* 2000). Sparrows nest in spring and early summer. Juvenile sparrows were captured when they moved beyond adult care. The juveniles formed flocks and migrated from midsummer. This flock-forming and migration to new feed sources by juveniles accords with previous observations about feeding efficiency of House Sparrows (Elgar and Catterall 1982). In winter, very few birds arrived, as presumably birds kept to known sheltered areas. These observations demonstrate that the best time to trap House Sparrows is between late January and June. Once House Sparrow numbers are low then the trap needs to be used on only the rare occasions when they arrive.

The best location of the trap is where it can be kept under observation. In other words, let the sparrows come to it rather than taking the trap to where the sparrows might be. Clearly House Sparrows are able to rapidly find a food source as was seen when newly arrived juvenile birds entered the trap within hours of arrival. Uneaten bait may attract vermin, so it is suggested that the trap should be on a hard surface to prevent them from burrowing under the edges to reach the grain. As finches need water, having a source of water close by, such as in a bird bath, may help in monitoring the presence of House Sparrows.

An important detail in the construction of the Weekly Times Sparrow Trap is the central V where a strip of netting is stretched across the framework. The instruction given must be followed carefully. It would assist the operation of the trap if the sides of the V are dark in color and the top of the central section above the V could be cov-

ered to exclude the overhead view of the sky. The Weekly Times Sparrow Trap is large and cumbersome to move. We constructed a smaller trap to enable easier operation, and other designs are also available.

These findings should encourage others to view House Sparrows as pests that can be eliminated with judicious trapping (care, skill and observation) and the removal of harbours. The present study demonstrates that House Sparrows are a problem that does not have to be tolerated.

Conclusion

The use of a trap, from late summer to midwinter, along with harbour removal, enabled the elimination of a population of House Sparrows. Sparrow traps were easily made, and worked effectively when supervised. We propose that in rural areas control at the homestead level is the most appropriate scale for effective elimination of House Sparrows. Use of this approach over a catchment scale should be able to eliminate or reduce House Sparrow populations. A larger scale trial would be a worthwhile exercise particularly in areas where native bird biodiversity is under threat.

Note

The removal of House Sparrows (considered vermin and with no statutory protection within the State of Victoria), was undertaken by private individuals. Although the authors have carefully documented the process and outcomes, first and foremost these were management actions and never undertaken as research actions. While ethics approval for these activities was not necessary, every effort was made to treat all trapped individuals ethically. As such the trap was only set when close supervision was possible, any trapped House Sparrows were removed and humanely killed soon after capture and the small number of non-target species that were captured were immediately released.

References

- Alley MR, Connolly JH, Fenwick SG, Mackereth GF, Leyland MJ, Rogers LE, Haycock M, Nicol C and Reed CEM (2002) An epidemic of salmonellosis caused by *Salmonella* Typhimurium DT160 in wild birds and humans in New Zealand. *New Zealand Veterinary Journal* **50**, 170-176.
- Anon. (1934) *The Weekly Times Farmers' Handbook*. (Herald and Weekly Times Ltd: Melbourne)
- Anon. (1978) *The Weekly Times Farmers' Handbook*. (Herald and Weekly Times Ltd: Melbourne)
- Anon. (1995) Home made sparrow trap. *Land For Wildlife Newsletter* **2** (7), 16.
- Anon. (2005) Bird Damage to Property. URL http://www.ancbirdcontrol.com.au/Effect_of_Feral_

- Birds in the Urban Environment.htm [accessed on 17 February 2005]
- Barrett G, Silcocks A, Barry S, Cunningham R and Poulter R (2003) *The New Atlas of Australian Birds*. (Birds Australia: Melbourne)
- Blakers M, Davies SJJF and Reilly PN (1984) *The Atlas of Australian Birds*. (Melbourne University Press: Melbourne)
- Bryant P (2002) Exotic Introductions. In *Biodiversity and Conservation, a hypertext book*, Chapter 14. URL <http://darwin.bio.uci.edu/~sustain/bio65/lec14/b65lec14.htm> [accessed on 5 November 2006]
- Chivers BL, Cowan PE, Waddington DC, Kelly PJ and Brown TJ (1998) The prevalence of infection of *Giardia* spp. and *Cryptosporidium* spp. in wild animals on farmland, southeastern North Island, New Zealand. *International Journal of Environmental Health Research* **8**, 59-64.
- Clergeau P, Levesque A and Lorvelec O (2004) The precautionary principle and biological invasion: the case of the House Sparrow on the Lesser Antilles. *International Journal of Pest Management* **50**, 83-89.
- Cruz, F, Donlan CJ, Campbell K and Carrion V (2005) Conservation action in the Galápagos: feral pig (*Sus scrofa*) eradication from Santiago Island. *Biological Conservation* **121**, 473-478.
- Donlan CJ, Tershy BR, Campbell K and Cruz F (2003) Research for requiems: the need for more collaborative action in eradication of invasive species. *Conservation Biology* **17**, 1850-1851.
- Elgar MA (1986) House sparrows establish foraging flocks by giving chirrup calls if the resources are divisible. *Animal Behaviour* **34**, 169-174.
- Elgar MA and Catterall CP (1982) Flock size and feeding efficiency in House Sparrows. *The Emu* **82**, 109-111.
- Gillbank L (2001) Animal acclimatisation: McCoy and the menagerie that became Melbourne's zoo. *The Victorian Naturalist* **118**, 297-304.
- Harkin EL, van Dongen WFD, Herberstein ME and Elgar MA (2000). The influence of visual observations on the vigilance and escape behaviour of house sparrows, *Passer domesticus*. *Australian Journal of Zoology* **48**, 259-263.
- Harrison DA and Congdon BC (2002) Wet Tropics Vertebrate Pest Risk Assessment Scheme. Report No 19. Cooperative Research Centre for Tropical Rainforest Ecology and Management, Cairns. URL http://www.rainforest-crc.jcu.edu.au/publications/vertebrate_pests.htm [accessed on 15 June 2005]
- Jensen H, Sæther B-E, Ringsby TH, Tufto J, Griffith SC and Ellegren H (2004) Lifetime reproductive success in relation to morphology in house sparrow *Passer domesticus*. *Journal of Animal Ecology* **73**, 599-611.
- Kern WH (2003) House or English Sparrow. Institute of Food and Agricultural Sciences, University of Florida. URL <http://edis.ifas.ufl.edu/UW119> [accessed on 1 November 2006]
- Long JL (1981) *Introduced Birds of the World*. (AH & AW Reed Publishing: Sydney) cited by Harrison and Congdon (2002).
- McInerney (2004) Help needed to guard against sparrows. URL <http://www.agric.wa.gov.au/newsindex.asp> [accessed on 25 May 2004]
- Rolls EC (1984) *They All Ran Wild*. 2 ed. (Angus and Robertson: Melbourne)
- Smallwood KS and Salmon TP (1992) A rating system for potential exotic bird and mammal pests. *Biological Conservation* **62**, 149-159.

Received 7 June 2007; accepted 11 October 2007

One Hundred Years Ago

EXCURSION TO THE YOU YANGS

In the surface of the granite several rock pools exist, which at the time of our visit were full of water, so that the tourist, except in the height of summer, should generally be able to secure water here, for as a rule the ranges are rather short of that commodity. A good spring also exists directly under the southern face of Station Peak.

From the largest of the pools I skimmed what I took to be a floating scum of fresh water algae, and, the situation being rather remarkable, I submitted it to Mr. A.D. Hardy, F.R.M.S., who has given me the following note:—"The material had unavoidably been much shaken up in transit, and appeared when received as a soapy green fluid with darker clots. Microscopically examined, it proved to be a mass of desmids of a single species only, *Closterium lanceolatum*, Kutzing, and, excepting numerous protozoa, no other organisms were present. This species occurs in various parts of Victoria, and was recorded from the weedy margins of Lake Colac a few years ago (*Vict. Nat.*, xxii, p. 66)."

The occurrence of an alga in such a remarkable position is most interesting, and shows that the most unlikely localities are often productive of unlooked-for results in both zoology and botany.

From *The Victorian Naturalist* XXV p. 126, December 10, 1908